

Application

MCL1 is a yarn break **capacitive sensor**, very versatile, used in winding, doubling, texturing, etc. process.

MAIN FUNCTION: Control the linear motion of any kind of textile yarns.

When the yarn breaks or when scrolling stops, **MCL1** will inform the user (flashing LED) that a position is defective. It can also activate a **yarn cutter** or stop the position giving a **LOW / HIGH signal** to an automate.

Any kind of material able to keep electrostatic charge can be checked by **MCL1**.

A specific version has been developed for Elasthane yarns (low speed).

PRINCIPLE: MCL1 probe will check the tension variations produced by the electrical charges into the yarn in motion. **MCL1** is insensitive to dust and vibrations.

ELECTRICAL PROTECTION: MCL1 is protected against reversed polarity and high level overload on output. It shows a very high level of EMC, electromagnetic compatibility: >4 kV.



Characteristics :

- Power supply : 18 to 30 V DC
- NPN or PNP Output
- Inhibition switch
- External inhibition input
- Visual alarm (red LED)
- Connection: through cable, Lumberg 2,5 MSFW 5 connector or any kind of connector on demand
- MCL1 sensitivity could be adapted to operator's requirement

These characteristics are adapted to operator's requirements. (Referenced to the codification board)

Dimensions (mm)

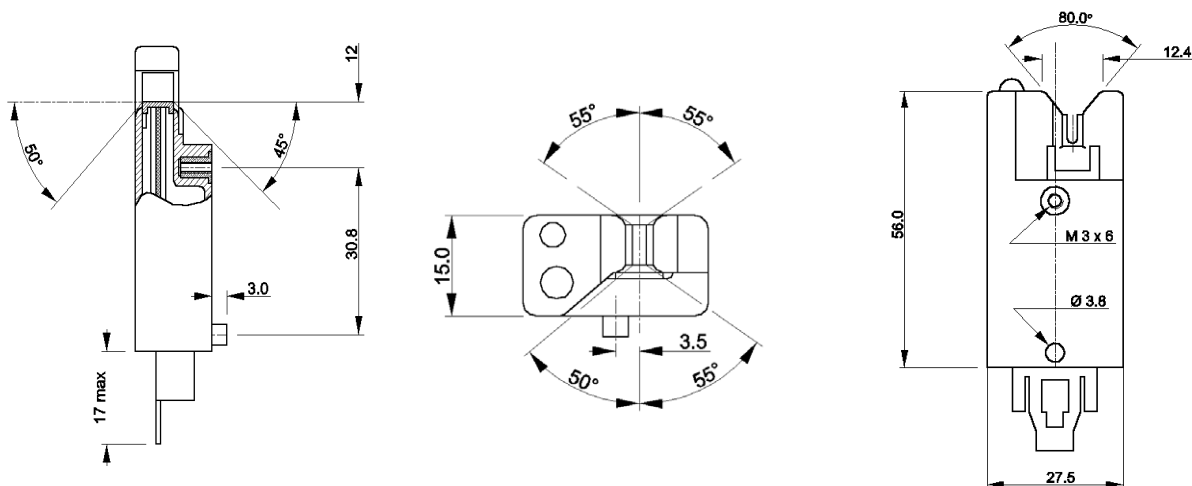

One of these guides can be adapted on the **MCL1** :



CA9-TD011 (Aluminium oxide)
 CA9-TD016 (Titanium oxide)



CA9-TD003 (Aluminium oxide)
 CA9-TD013 (Zirconium aluminium)



CA9-TD014 (Zirconium aluminium)
 CA9-TD015 (Aluminium oxide)

Characteristic codification

MCL1

Capacitive sensor range

MCL1-			X	X	X	X	X
Inhibition / Pilot light / Inhibition							
Push button	LED	External input					
Without	Without	Without	1				
With	Without	Without	2				
Without	With	Without	3				
With	With	Without	4				
Without	Without	With	5				
With	Without	With	6				
Without	With	With	7				
With	With	With	8				
Guides							
Without guide				0			
CA9-TD011				1			
CA9-TD003				2			
CA9-TD013				3			
CA9-TD014				4			
CA9-TD015				5			
CA9-TD016				6			
Connections							
By cable					1		
By connector					2		
Response time (ms)							
100						3	
200						4	
600						5	
900						6	
Output							
NPN Normally open (NO)							1
PNP Normally open (NO)							2
NPN Normally close (NC)							3
PNP Normally close (NC)							4

Example

MCL1-80261 :

- 8 : with push-button, LED and external inhibition input
- 0 : without guide
- 2 : with Lumberg 2,5 MSFW 5 connector
- 6 : response time of 900 ms
- 1 : NPN output Normally Open (NO)

Sensors from the new range can be mounted on the FIL CONTROL standard rail (ref. : 423800), by the mean of bracket (ref. : 423802).

Technical characteristics

Parameters	Conditions	Min	Typ	Max
Power supply voltage (V)		18	24	30
Sensor consumption (mA)	Own current consumption at 24 V DC and at 25°C. External inhibition and output not connected	-	22	25
	Indicator light ON	-	7,5	10,5
	Indicator light OFF	-	-	-
Ripple voltage at 100 Hz	Supply voltage peaks < 30 V	-	-	80%
Delay between detection and move start (s)	On request	-	3	-
Dropout voltage at the output (V)	Output current < 1 A	-	1,2	1,6
Min. current driven by the output (A)	Voltage at the output < 32 V	1	-	-
Max. voltage at the output (V)		-	-	50
Logical level on the inhibition input (V)	Supply voltage = 24 V			
	High level	10,7	-	-
	Low level	-	-	3,8
Current in the inhibition input (mA)	Supply voltage = 24 V			
	Low level	-	-	5,3
Immunity to the perturbations (kV)	Positive and negative			
	Injected	4	-	-
	Inducted	4	-	-
	Radiated	4	-	-
Temperature range (°C)				
	For storage	-25	-	85
	For operation	0	-	50
Relative humidity		-	-	80%

Setting up procedure

Standard connection

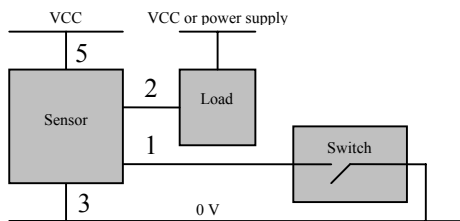

Standard configuration Output NPN-NO

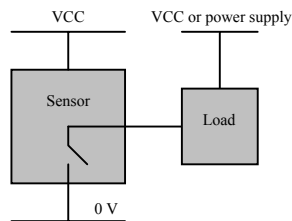

Other configuration Output PNP-NO

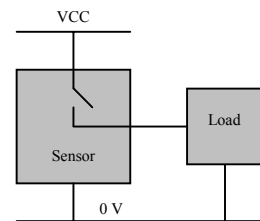

1 : External inhibition input
 2 : NPN output

Presence of yarn

Presence of yarn

Global Operations

State	LED	Output	External input
Switch-on	Light-on	Inactive	Active level 0 (0V) Inactive level 1 (24V)
Inhibition	Light-on	Inactive	
Presence of yarn	Light-off	Inactive	
Absence of yarn	Blinking	Active	